



ENGINE

Model	FPT F4HFE613J
Emissions Certification	Tier 4 Interim Certified
Cylinders	6
Displacement	409 in ³ (6.7 L)
Fuel injection	Common rail
Fuel	#2 Diesel
Fuel filter	Spin-on w/ in-line strainer
Air intake	Cross-flow
Cooling	Liquid
Engine speeds	RPM
High idle - no load	2200 +/- 50
Rated - full load	2000
Low idle	800 +/- 25
Horsepower @ 2000 RPM – SAE J1349:	
Net	214 hp (160 kW)
Gross	232 hp (173 kW)
Engine lubrication:	
Pump	Deep sump plate cooler w/ pressurized under-piston nozzles
Pump operating angle ratings:	
Side-to-side	35°
Fore and aft	45°
Oil filtration	Replaceable, spin-on full-flow cartridge
Radiator:	
Fins per inch	10
Fan:	
Type	Variable speed/ Auto reversing/Hydraulic driven
Diameter	27.6 in (700 mm)

DRIVETRAIN

Dual path hydrostatic:	
Pump	Variable axial piston
Motor	Variable bent axis piston
Max. drawbar pull*	80,979 lb (360 kN)
Transmission	Single lever control – electronic straight tracking
Transmission oil filter	4 micron at beta 75, replaceable w/ 100 mesh suction screen
Travel speeds*:	
Forward	5.8 mph (9.3 kph)
Reverse	5.8 mph (9.3 kph)
Parking brakes	Heavy-duty, spring-applied, hydraulic pressure release
Steering brakes	Hydrostatic
Final drive	2 helical gear reduction to planetary output
Ratio	48.75:1
Transmission cooling:	
Type	Tube and fin
Core size	510.1 in ² (0.33 m ²)

NOTE: *Measured using standard track chain. Increase travel speeds by 4% and reduce drawbar pull by 4% with the optional CELT track chain.

ELECTRICAL

Alternator	120 amp
Battery	(2) 12-volt, low-maintenance 950 cold-cranking amps @ 0° F (-18° C)
Electrical System	24 Volts

OPERATOR ENVIRONMENT

Fully enclosed ROPS cab; Single lever control for speed, steering and direction; Cloth air suspension seat w/ back adjustment; Retractable 2 in (51 mm) seat belt; Adjustable armrest; Two foot rest; Rearview mirror; Two door windshield wipers; Dome light; 12-volt accessory outlet; Headliner; Floor mat.

Warning lights:

Air filter; Alternator; Diagnostic fault indicator; Engine coolant temperature; Engine oil pressure; Hydraulic filter; Low fuel level; Park brake engaged; Service soon indicator; Transmission filter; Transmission charge pressure.

Gauges:

Battery voltage; Fuel level; Digital hour meter/tachometer/diagnostic/service reminder; Transmission oil temperature; Transmission speed indicator; Water temperature; Diesel Exhaust Fluid (DEF) level.

Audible warnings:

Engine coolant temperature; Engine oil pressure; Low fuel level; Transmission charge pressure; Temperature/hydraulic temperature.

OPERATING WEIGHT

Unit equipped w/ cab, full fuel tank, 170 lb (77 kg) operator, rear retrieval hitch, track guides, PAT blade.

Extra long track	45,414 lb (20 599 kg)
Wide track	46,891 lb (21 269 kg)
Low ground pressure	48,773 lb (22 123 kg)

Add-on weights:

Drawbar	146 lb (66 kg)
Ripper – 3 shank	2,988 lb (1 355 kg)
CELT chain:	
24 in (610 mm) – XLT/WT	190 lb (86 kg)
28 in (711 mm)	190 lb (86 kg)
30 in (762 mm)	185 lb (84 kg)
36 in (914 mm)	190 lb (86 kg)
Center rock guard	675 lb (306 kg)
Sweeps	139 lb (63 kg)

HYDRAULICS

Pump flow @ 2200 RPM @ 2,830 psi (19 512 kPa)	40.4 gpm (153 L/min)
--	----------------------

Lift cylinder w/ PAT	Two (2)
Bore diameter	4.50 in (114.3 mm)
Rod diameter	2.50 in (63.5 mm)
Stroke	19.21 in (488.0 mm)

Angle cylinder w/ PAT	Two (2)
Bore diameter	4.50 in (114.3 mm)
Rod diameter	2.50 in (63.5 mm)
Stroke	19.79 in (502.7 mm)

Tilt cylinder w/ PAT	One (1)
Bore diameter	5.00 in (127.0 mm)
Rod diameter	2.50 in (63.5 mm)
Stroke	5.84 in (148.4 mm)

Lift cylinder – Bulldozer	Two (2)
Bore diameter	3.25 in (82.6 mm)
Rod diameter	2.00 in (50.8 mm)
Stroke	39.37 in (1 000 mm)

Tilt cylinder – Bulldozer	One (1)
Bore diameter	4.50 in (114.3 mm)
Rod diameter	2.50 in (63.5 mm)
Stroke	4.96 in (126.0 mm)

SERVICE CAPACITIES

Fuel tank	107.0 gal (405.0 L)
Engine oil w/ filter	17.3 qt (16.4 L)
Engine oil w/o filter	16.5 qt (15.6 L)
Engine cooling system	8.0 gal (30.28 L)
Hydraulic reservoir	55.0 gal (210.0 L)
Final drive – per side	26.4 qt (25.0 L)
Track rollers – each	0.29 qt (0.275 L)
Front idlers – each	0.237 qt (0.225 L)
Carrier rollers – each	0.353 qt (0.334 L)
DEF tank	14.0 gal (52.0 L)

OTHER SPECIFICATIONS

Undercarriage:	
Track adjustment	Hydraulic
Frame	Pivot shaft and oscillating equalizer beam suspension
Length of track on ground	129 in (3.30 m)
Track link pitch	7.98 in (202.8 mm)
Track shoe height	2.81 in (71.5 mm)
Pin diameter	1.75 in (44.5 mm)
Bushing diameter:	
CLT track	2.86 in (72.7 mm)
CELT track	3.67 in (93.2 mm)
Track shoes per side	45
Track rollers per side	8
Carrier rollers per side	2
Track roller rail diameter	7.38 in (187.6 mm)

Track on ground:	
Shoe area:	
24 in (610 mm)	5,002 in ² (32 269 cm ²)
24 in (610 mm)	6,197 in ² (39 979 cm ²)
28 in (711 mm)	7,223 in ² (46 559 cm ²)
30 in (762 mm)	7,741 in ² (49 941 cm ²)
36 in (914 mm)	9,285 in ² (59 904 cm ²)

Track:	
Extra long track:	
24 in (610 mm)	closed grousers and CLT
24 in (610 mm)	open grousers and CELT
Wide track:	
28 in (711 mm)	closed grousers and CLT
28 in (711 mm)	open grousers and CELT
30 in (762 mm)	closed grousers and CLT
30 in (762 mm)	open grousers and CELT
Low ground pressure:	
36 in (914 mm)	closed grousers and CLT
36 in (914 mm)	open grousers and CELT

Blade:	
Variable blade pitch	55° – 60°
Lift speed – per second	19.0 in (483 mm)
Cutting edge – PAT	Reversible, replaceable
Width	10.0 in (254 mm)
Thickness	0.8 in (20 mm)

Ripper:	
Max. penetration	20.0 in (507 mm)
Width	76.9 in (1 953 mm)
Cut width	74.4 in (1 890 mm)
Max. ground clearance	12.8 in (325 mm)
Max. number of shanks	3
Tooth spacing:	
w/ 3 teeth	37.2 in (945 mm)
Hydraulic cylinder	
Diameter	6.14 in (156 mm)
Stroke	23.5 in (597 mm)
Rod	2.75 in (70 mm)

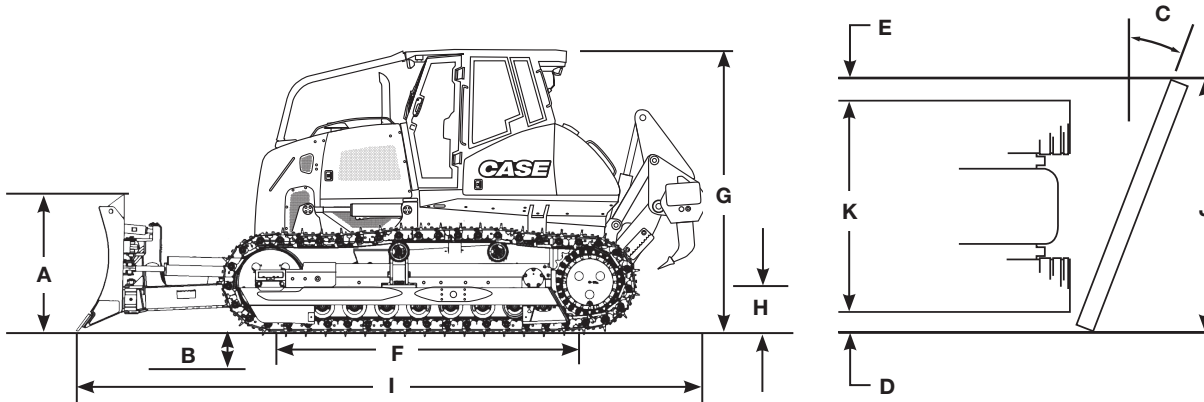

Line drawings are for illustrative purpose only and may not be exact representation of unit.

DIMENSIONS

	Extra Long Track (XLT) with Semi-U	Extra Long Track (XLT) with PAT	Low Ground Pressure (LGP) with Straight PT	Low Ground Pressure (LGP) with PAT
Blade width	134.7 in (3 422 mm)	142 in (3 607 mm)	154 in (3 900 mm)	157.5 in (4 064 mm)
SAE blade capacity	7.29 yd ³ (5.57 m ³)	6.32 yd ³ (4.83 m ³)	4.94 yd ³ (3.78 m ³)	7.12 yd ³ (5.54 m ³)
A. Blade height	56 in (1 418 mm)	53.8 in (1 366 mm)	43.5 in (1 105 mm)	53.9 in (1 369 mm)
Blade lift above ground	49 in (1 244 mm)	44.5 in (1 130 mm)	46 in (1 169 mm)	44.5 in (1 130 mm)
B. Blade depth below ground	23 in (584 mm)	23.2 in (590 mm)	21.5 in (545 mm)	23.2 in (590 mm)
C. Blade angle both directions	–	28°	–	28°
D. Cast reach	17.3 in (438.9 mm)	22.7 in (576.4 mm)	14.3 in (363 mm)	18.6 in (472.1 mm)
E. Cut reach	17.3 in (438.9 mm)	5.7 in (145.7 mm)	14.3 in (363 mm)	1.7 in (43.0 mm)
Blade tilt, each end	17 in (433 mm)	21.7 in (550 mm)	16.2 in (411 mm)	21.7 in (550 mm)
Track gauge	76 in (1.94 m)	76 in (1.94 m)	89 in (2.26 m)	89 in (2.26 m)
Maximum shoe width	24 in (609 mm)	24 in (609 mm)	36 in (914 mm)	36 in (914 mm)
F. Length of track on ground	129 in (3.28 m)	129 in (3.28 m)	129 in (3.28 m)	129 in (3.28 m)
Area of track on ground	7,223 in ² (4.66 m ²)	7,223 in ² (4.66 m ²)	9,285 in ² (5.99 m ²)	9,285 in ² (5.99 m ²)
Ground pressure	7.33 psi (0.51 bar)	7.33 psi (0.51 bar)	5.25 psi (0.36 bar)	5.25 psi (0.36 bar)
G. Height to top of cab	10 ft 2 in (3 103 mm)	10 ft 2 in (3 103 mm)	10 ft 2 in (3 103 mm)	10 ft 2 in (3 103 mm)
Height to top of exhaust	9 ft 5 in (2 876 mm)	9 ft 5 in (2 876 mm)	9 ft 5 in (2 876 mm)	9 ft 5 in (2 876 mm)
H. Ground clearance	12.8 in (325 mm)	12.8 in (325 mm)	12.8 in (325 mm)	12.8 in (325 mm)
Length:				
Blade straight with drawbar	17 ft 7 in (5 359 mm)	19 ft 4 in (5 902 mm)	19 ft 3 in (5 867 mm)	19 ft 4 in (5 902 mm)
I. Blade straight with ripper	22 ft 5 in (6 833 mm)	24 ft 2 in (7 366 mm)	22 ft 9 in (6 934 mm)	24 ft 2 in (7 366 mm)
Width:				
Blade straight	11 ft 2 in (3 404 mm)	11 ft 8 in (3 556 mm)	12 ft 8 in (3 861 mm)	13 ft 3 in (4 039 mm)
J. Blade angled	–	10 ft 9 in (3 287 mm)	12 ft 1 in (3 690 mm)	11 ft 9 in (3 625 mm)
K. Over track	8 ft 3 in (2 515 mm)	8 ft 3 in (2 515 mm)	10 ft 4 in (3 150 mm)	10 ft 4 in (3 150 mm)

STANDARD EQUIPMENT

OPERATOR ENVIRONMENT

See page 1

ENGINE

F4HFE613J
Tier 4 Interim Certified
Automatic fan belt tensioner
Integral engine oil cooling
Fuel filter
Dual element radial seal air cleaner
120 amp alternator
(2) 950 CCA 12-volt batteries
Anti-sandblast radiator
Engine side panels

DRIVETRAIN

Dual path infinitely variable, single-lever controlled hydrostatic drive, with electronic straight tracking and counter-rotation
Final drive:
Triple reduction; helical gear/planetary decelerator with hydrostatic drive retardation
Automatic spring-applied parking brake

BLADE

55° – 60° variable pitch
Single lever electro-hydraulic control for blade lift, angle and tilt

UNDERCARRIAGE

Hydraulic track adjusters
Case Lubricated Track Chain
Permanently lubricated track and carrier rollers
Track adjuster guard
Track guides – front and rear

OTHER

Anti-vandalism package
Backup alarm
Horn
Work lights:
2 front
1 rear
Master disconnect switch
Mirror
Pre-cleaner
Front pull hook
Rear transmission guard

TELEMATICS

CASE SiteWatch™ Telematics – includes hardware and a 3-yr Advanced data subscription

OPTIONAL EQUIPMENT

OPERATOR ENVIRONMENT

Cab air quality system
Seat belt – 3 in (76 mm)
Rear wiper for cab
Radio

HYDRAULICS

4-spool hydraulic valve for field-installed ripper
3-spool hydraulic valve without plugs for field-installed ripper
3-spool hydraulic valve with plugs

REAR MOUNTED EQUIPMENT

Ripper – 3 position with 3 shanks
Rear tow hook
Drawbar
Drawbar with step

BLADES

PAT – 142 in (3 607 mm)
PAT – 160 in (4 064 mm)
Folding PAT – 160 in (4 064 mm)
HS Straight (WT/LGP) – 154 in (3 900 mm)
Semi-U – 135 in (3 422 mm)

GUARDS

CAB canopy brush guard
Full length rock guards

SCREENS

Cab rear screen

OTHER

Environmental drains
Case Extended Life Track
Cold start – grid heater
Additional work lights
Blade guidance ready – Trimble
Blade guidance ready – Leica
Blade guidance ready – Topcon
Rearview implement mirror
Turbine pre-cleaner

CaseCE.com

©2015 CNH Industrial America LLC. All rights reserved. CASE is a trademark registered in the United States and many other countries, owned by or licensed to CNH Industrial N.V., its subsidiaries or affiliates. CNH Industrial Capital is a trademark in the United States and many other countries, owned by or licensed to CNH Industrial N.V., its subsidiaries or affiliates. Printed in U.S.A. Contains 10% post-consumer fiber.

IMPORTANT: CASE Construction Equipment Inc. reserves the right to change these specifications without notice and without incurring any obligation relating to such change. Availability of some models and equipment builds vary according to the country in which the equipment is used. The illustrations and text may include optional equipment and accessories and may not include all standard equipment. Your CASE dealer/distributor will be able to give you details of the products and their specifications available in your area.



CASE Construction Equipment is biodiesel-friendly. NOTE: All engines meet current EPA emissions regulations. All specifications are stated in accordance with SAE Standards or Recommended Practices, where applicable.



Always read the Operator's Manual before operating any equipment. Inspect equipment before using it, and be sure it is operating properly. Follow the product safety signs and use any safety features provided.

Form No. CCE2015122050M
Replaces Form No. CCE2015032050M

2050M

3 of 3